

## **Technical Specifications and Connections**

---



# Informazione sulla pubblicazione

<b>Lista degli Aggiornamenti</b>			
<b>Revisione</b>	<b>Aggiunto</b>	<b>Eliminato</b>	<b>Modificato</b>
00	Not Emitted		
01	First Revision		

**CNI ENGINEERING S.r.l.**

Nessuna parte di questo manuale può essere riprodotta o trasmessa in qualsiasi forma o modo elettronico o meccanico, compresa la fotocopiatura, senza l'espressa autorizzazione scritta della **CNI Engineering**.

**PUBLICATION ISSUED BY:**

**Documentation office**



Via Carpanelli, 24  
40011 Anzola dell'Emilia (Bo) Italy  
Tel. +39 051 6508911  
Fax +39 051 6508912  
Info@cnicnc.com  
www.cnicnc.com

**Registered offices**

Via dell'Artigianato, 1  
48011 Alfonsine (Ra) Italy  
Tel. +39 0544 84277  
Fax +39 0544 80635  
P.I. e C.F. 02248390391

Document Code: **H5834D0090ING**

Document revision: **01**

Document edition: **05/15/2007**



## INDEX

<b>1</b>	<b>INTRODUCTION .....</b>	<b>1</b>
1.1	Warnings and basic safety precautions .....	1
1.1.1	Purpose of this manual .....	1
1.2	Symbols used in this manual .....	1
1.3	Risks associated with the product .....	2
1.3.1	Risks associated with improper use and handling .....	2
1.4	Warranty .....	2
<b>2</b>	<b>PACKAGING, TRANSPORT AND STORAGE .....</b>	<b>3</b>
2.1	Transport .....	3
2.2	Storage .....	3
<b>3</b>	<b>TECHNICAL DESCRIPTION .....</b>	<b>5</b>
3.1	General data .....	5
<b>4</b>	<b>INSTALLATION.....</b>	<b>7</b>
4.1	Control Panel CP1202 (CP1302) Arm connection .....	7
4.1.1	PLC Console CP1200 .....	8
4.1.2	PLC Console CP1300 .....	8
4.1.3	H0108D1002Bx: dimensions .....	9
4.1.4	H0108D1x02Bx: dimensions .....	10
4.2	Built-in Console CP1022 with C11000B Box .....	11
4.2.1	Built-in Console CP1022: dimensions .....	12
4.2.2	Built-in Console CP1022B: dimensions .....	13
4.3	Electrical connections .....	14
4.3.1	CP1x02 Console (Arm connection) .....	15
4.3.2	CP1022 Console (Built-in) .....	17
<b>5</b>	<b>MAINTENANCE.....</b>	<b>19</b>
5.1	Scheduled maintenance .....	19



### 1 INTRODUCTION

#### 1.1 Warnings and basic safety precautions

##### 1.1.1 Purpose of this manual

This manual is an integral part of the product and must accompany it at all times. Removal of this manual from the product constitutes removal of one of the product's essential safety requisites. Keep this manual safe, and make sure that it is distributed to and available to all persons involved with the product.

This manual contains safety precautions essential to safeguarding the health and safety of all persons exposed to residual risks.

The instructions in this manual provide essential information on how to operate the product correctly and in accordance with the manufacturer's requirements.

If you encounter any inconsistencies between the instructions in this manual and any applicable safety precautions, contact **CNI - HSD** to have the necessary corrections and/or modifications introduced.

Make sure that you have read and fully understood all the documentation supplied with the product to avoid operating it in ways that could cause injury to persons and/or damage to the product itself. Keep this manual in a suitable place, where it is always readily available for consultation.



**The information contained in this manual is essential for the safe and correct use of the product.**

#### 1.2 Symbols used in this manual

<p><b>WARNING</b></p>	<p><b>This symbol identifies a procedure, instruction or precaution that, if ignored or performed incorrectly, may result in personal injury.</b></p>
<p><b>CAUTION</b></p>	<p><b>This symbol identifies a procedure, instruction or precaution that, if ignored or performed incorrectly, may result in damage to or destruction of the product.</b></p>
<p><b>IMPORTANT</b></p>	<p><b>This symbol identifies particularly important general information that must not be ignored.</b></p>

## 1.3 Risks associated with the product

CNI - HSD does not and cannot know how end users will install the product. The installer or customer must therefore perform a separate risk assessment for each installation and application.

### 1.3.1 Risks associated with improper use and handling

Never impede the function of, remove, modify, or in any way interfere with any safety device, guard, or control of any individual parts or of the product as a whole.

- Do not use the product in atmospheres or environments where there is a risk of explosion.
- Unless you are qualified and authorised to do so, never attempt to repair faults or malfunctions and never interfere in any way with the product's operation or installation.
- Maintain all protection and safety devices in perfect working order. Also make sure that all warning labels and symbols are correctly positioned and perfectly legible.

## 1.4 Warranty

HSD declares and confirms that this product has passed all relevant Quality Control tests in the factory.

**All work performed under the terms of the warranty shall be carried out at the premises of HSD, with carriage at the customer's expense. HSD cannot accept any responsibility for production losses incurred as a result of work performed under warranty.**

HSD declines all responsibility for non-compliance of the product caused by failure to follow the precautions and instructions given in this manual or by improper use or handling of the product. **The customer has a right to the replacement of all parts shown to be defective, unless the said defects are caused by unauthorised tampering, including the fitting of non-original HSD spare parts and/or the replacement of parts not described or authorised in this manual unless authorised beforehand and in writing by HSD.**

**In no case shall HSD or its suppliers accept any responsibility for damage (including damage to the unit, damage incurred through lost production and income, down-time in manufacturing, loss of information or other economic losses) deriving from the use of HSD products, even if HSD has been advised in advance of the risk of such damage.**

The warranty becomes automatically null and void if the customer fails to notify HSD in writing of any faults found within 15 days of their occurrence. The warranty likewise becomes null and void if the customer fails to permit the seller to perform all necessary checks and tests, and if, when the seller requests the return of a defective part, the customer fails to do so within two weeks of the request.

Dimensioned drawings and photographs are provided only for information purposes and to facilitate the understanding of text.

HSD applies a policy of continuous development and improvement, and reserves the right to make functional and stylistic modifications to its products, to change the design of main or secondary parts, and to suspend manufacturing and supply without notice and without obligation to third parties. Furthermore, HSD reserves the right to make any structural or functional changes to the units, and to change the supply of spare parts and accessories without any prior notice.

## 2 PACKAGING, TRANSPORT AND STORAGE

Check that the packaging and the product itself are undamaged as soon as you open the box. Contact the supplier immediately if you notice any damage.



**When you unpack the product, dispose of unwanted packaging material in compliance with applicable recycling and waste disposal standards and regulations.**

### 2.1 Transport

Given the product's small size, it can be easily carried.

When lifting and moving the product, take great care to avoid dropping it and also avoid any unnecessary impact that could cause malfunctioning or damage to delicate parts.

### 2.2 Storage

If the product is going to be warehoused or stored for an extended period of time, make sure that it is adequately protected against the weather and any potential sources of damage in the storage environment (rain, humidity, dust, chemicals, etc.).

The CP1000 console is delivered in a wrapping that protects it against electro-static discharge.

Temperature range in storage	-25°C ÷ +70°C (-13°F ÷ +158°F)
Maximum storage altitude	2000m (6500ft)
Relative humidity without condensation	10% ÷ 95%



### 3 TECHNICAL DESCRIPTION

#### 3.1 General data

OPERATING ENVIRONMENT	
<i>Temperatura</i>	5°C ÷ 40°C (41°F ÷ 104°F)
<i>Massima altitudine di funzionamento</i>	2000m (6500ft)
<i>Umidità relativa senza condensazione</i>	10% ÷ 95%
<i>Zona di impiego del dispositivo</i>	Zona A
<i>Grado di inquinamento</i>	2
<i>Classe di sovratensione</i>	II
<i>Classe di protezione IP</i>	IP20

Access to the inside of CP1000 control board must be reserved solely to authorised personnel. The control board is intended for use in industrial environments. The user must verify that the environmental conditions comply with those indicated. If the environmental conditions are different from those described, the user must contact the producer.

VERSION	CODC	DESCRIPTION
<b>CP1002</b> Arm connection	<b>H0108D1002A0</b>	15" Display LCD - Extended keyboard
	<b>H0108D1002A1</b>	15" Display LCD - Extended keyboard with Touch-Pad
	<b>H0108D1002A2</b>	15" Display LCD - Touch-Screen
	<b>H0108D1002A3</b>	15" Display LCD
<b>CP1202</b> Arm connection+ CP1200 PLC console	<b>H0108D1202A0</b>	15" Display LCD - Extended keyboard - CP1200 console
	<b>H0108D1202A1</b>	15" Display LCD - Extended keyboard with Touch-Pad - CP1200 console
	<b>H0108D1202A2</b>	15" Display LCD - Extended keyboard with Touch-Screen - CP1200 console
	<b>H0108D1202A3</b>	15" Display LCD - CP1200 console
<b>CP1202B</b> Arm connection+ CP1200 PLC console	<b>H0108D1202B0</b>	15" Display LCD - Extended keyboard - CP1200 console
	<b>H0108D1202B2</b>	15" Display LCD - Extended keyboard with Touch-Screen - CP1200 console
	<b>H0108D1202B3</b>	15" Display LCD - CP1200 console
	<b>H0108D1202B4</b>	15" Display LCD - CP1200 console - Top connection
	<b>H0108D1202B5</b>	15" Display LCD - Extended keyboard with Touch-Screen - CP1200 console - Top connection
<b>CP1302</b> Arm connection+ CP1300 PLC console	<b>H0108D1302A0</b>	15" Display LCD - Extended keyboard - CP1300 console
	<b>H0108D1302A1</b>	15" Display LCD - Extended keyboard with Touch-Pad - CP1300 console

continue to next page

from previous page		
VERSION	CODE	DESCRIPTION
CP1022 Built-in	H0108D1022A0	15" Display LCD - Extended keyboard
	H0108D1022A1	15" Display LCD - Extended keyboard with Touch-Pad
CP1022B Built-in	H0108D1022B1	15" Display LCD - Extended keyboard with Touch-Pad

**N.B.** - Those with CP1xx2B codes have a metal casing with a uniform depth (56 mm).

***Dati tecnici:***

**CP1302 console - Arm connection**

Power supply voltage	12 Vdc
Max. absorbed current	2.5 A
Display	LCD 15"

**CP1022 Console (Built-in)**

Display	LCD 15"
---------	---------

### 4 INSTALLATION

#### 4.1 Control Panel CP1202 (CP1302) Arm connection

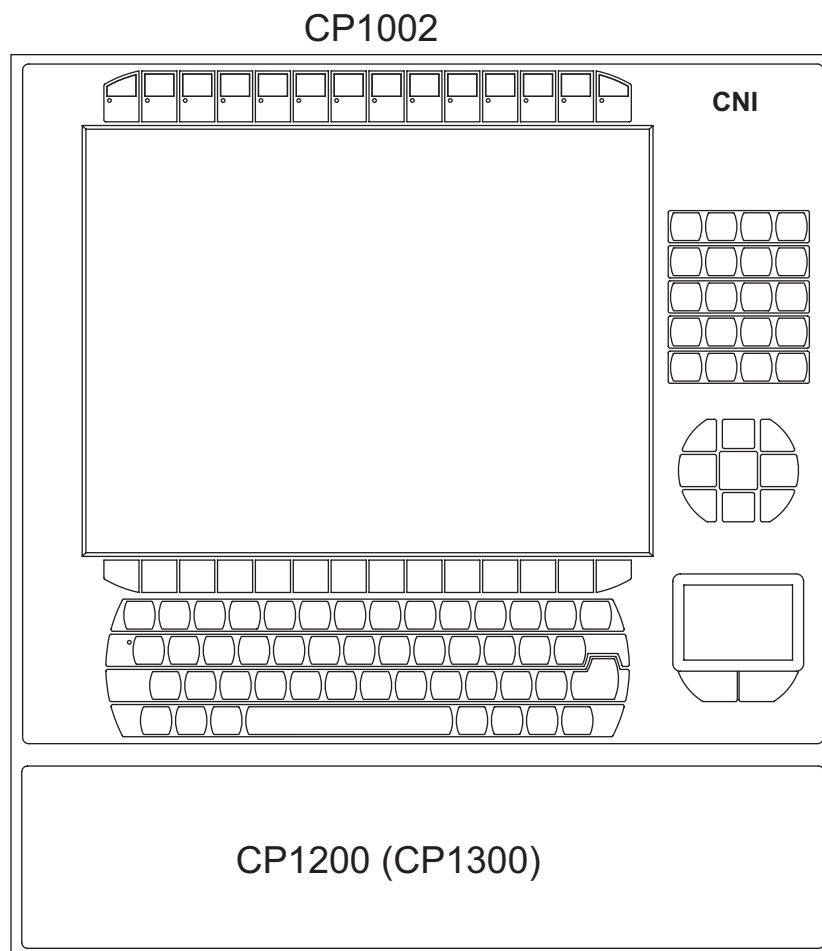

**Legend:**

- CP1002** Console with 15" LCD Display + Expanded Keyboard + Touch-Pad
- CP1200** Plc Keyboard
- CP1300** Plc Keyboard + Override (version without Floppy drive)

4.1.1 PLC Console CP1200

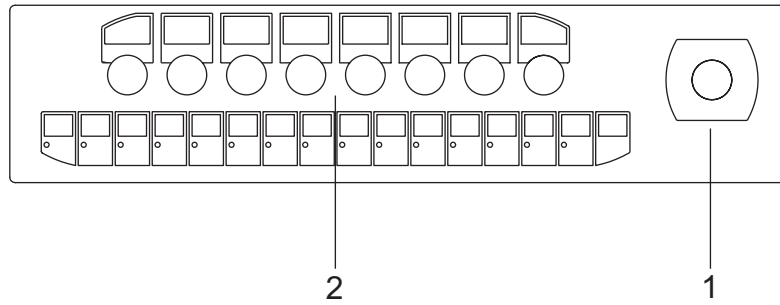

**Legenda:**

- 1. Emergency pushbutton
- 2. PLC Keyboard

4.1.2 PLC Console CP1300

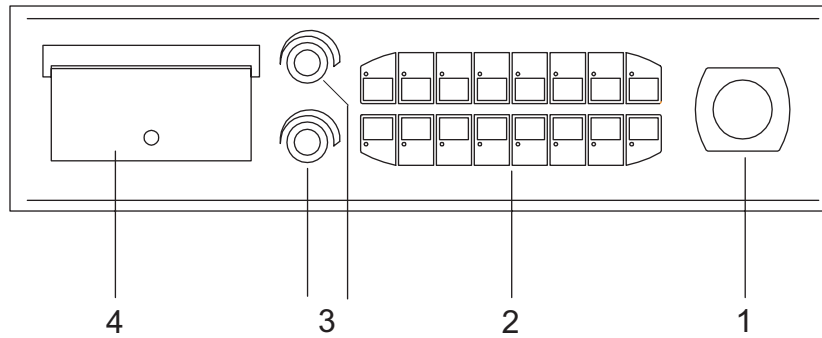

**Legenda:**

- 1. Emergency pushbutton
- 2. PLC keyboard
- 3. Override knob
- 4. See next Table

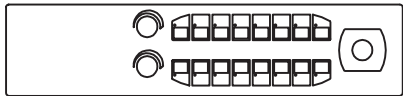
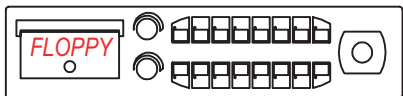
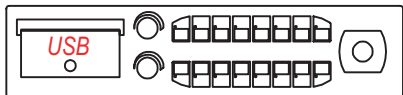
VERSION	CODE	
CP1300 BASIC for Arm connection & Built-In versions	H0601D0074	
CP1300 FLOPPY: only for Built-In version	H0601D0069	
CP1300 USB only for Built-In version	H0601D0085	

### 4.1.3 H0108D1002Bx: dimensions

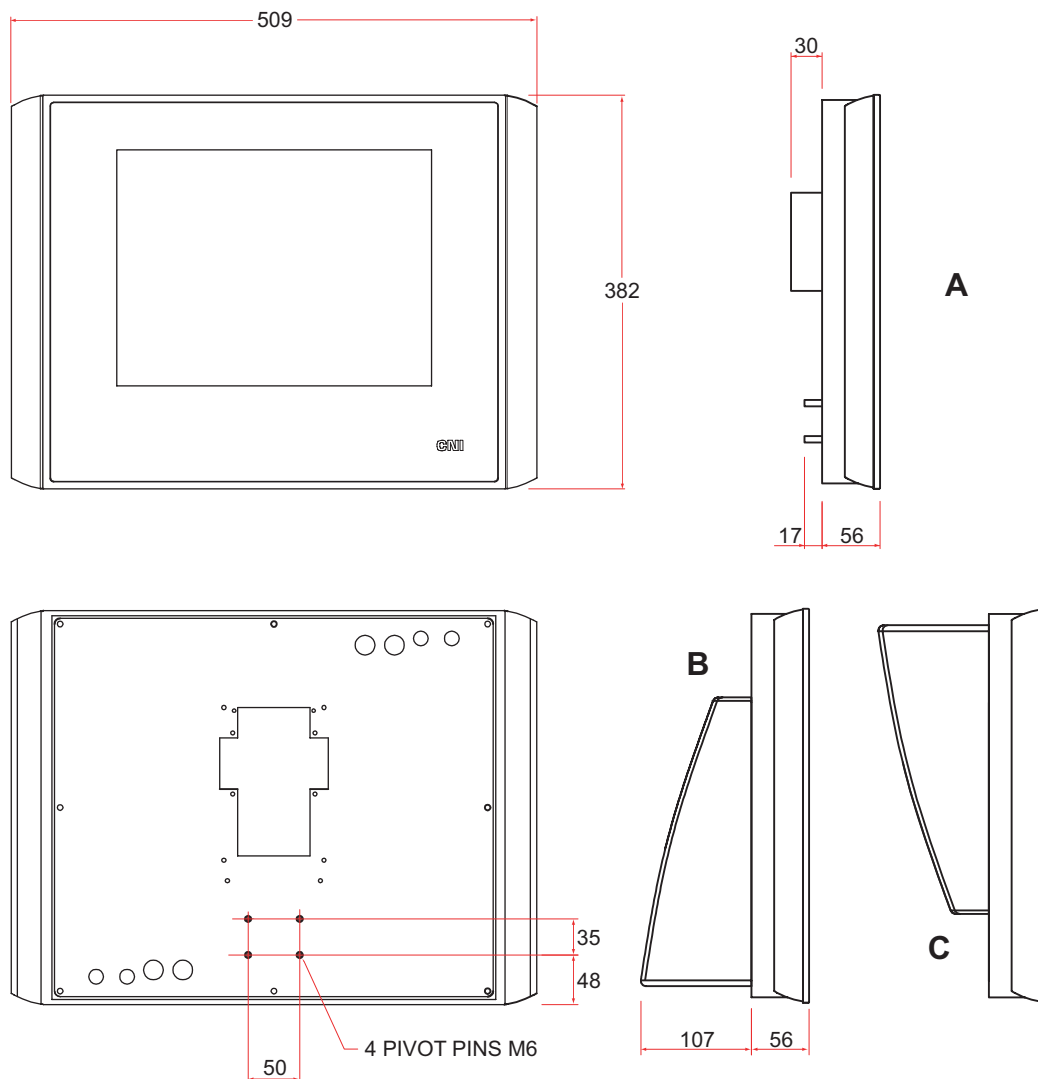

**Legend:**

- A** Control board without rear casing for mobile arm connection
- B** Control board with rear casing for connection of the arm from below (standard)
- C** Control board with rear casing for connection of the arm from above

4.1.4 H0108D1x02Bx: dimensions

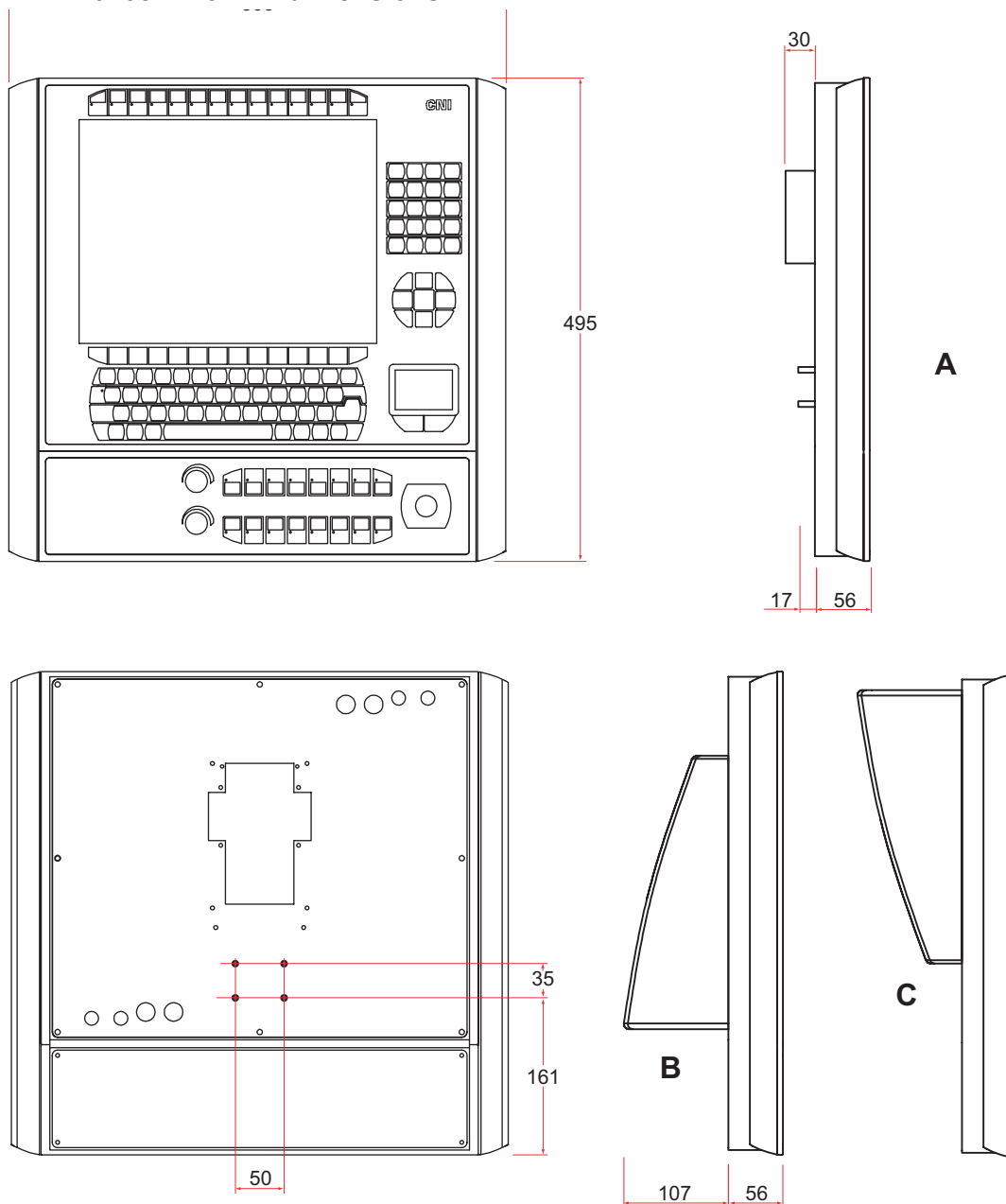

**Legend:**

- A** Control board without rear casing for mobile arm connection
- B** Control board with rear casing for connection of the arm from below (standard)
- C** Control board with rear casing for connection of the arm from above

### 4.2 Built-in Console CP1022 with CI1000B Box

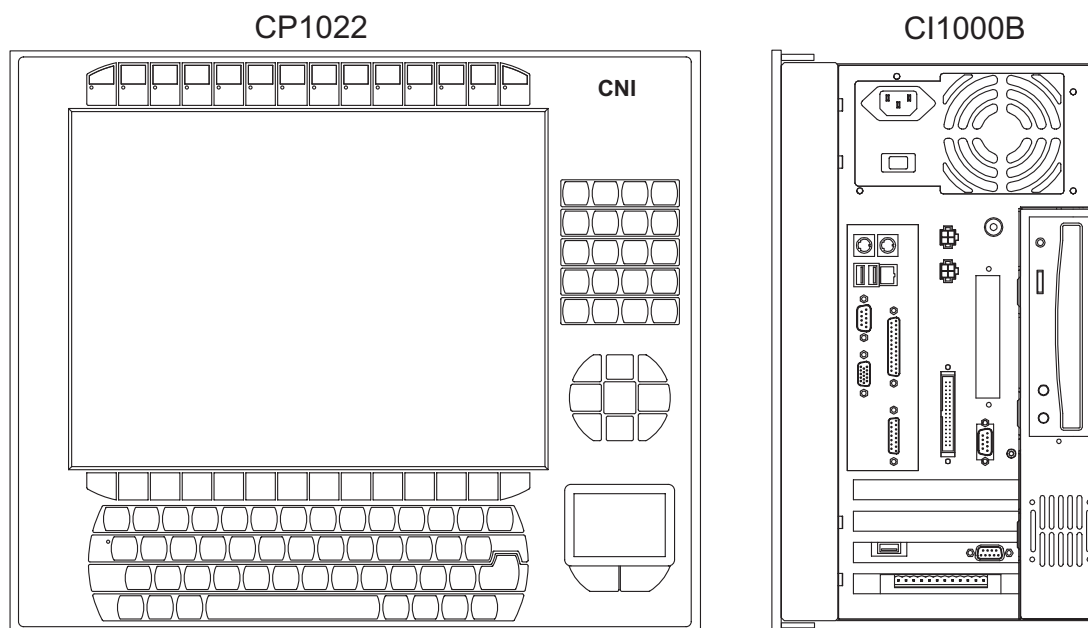

**Legend:**

- CP1002** Console with 15" LCD Display + Expanded Keyboard + Touch-Pad
- CI1000B** Box with Industrial Pc

4.2.1 Built-in Console CP1022: dimensions

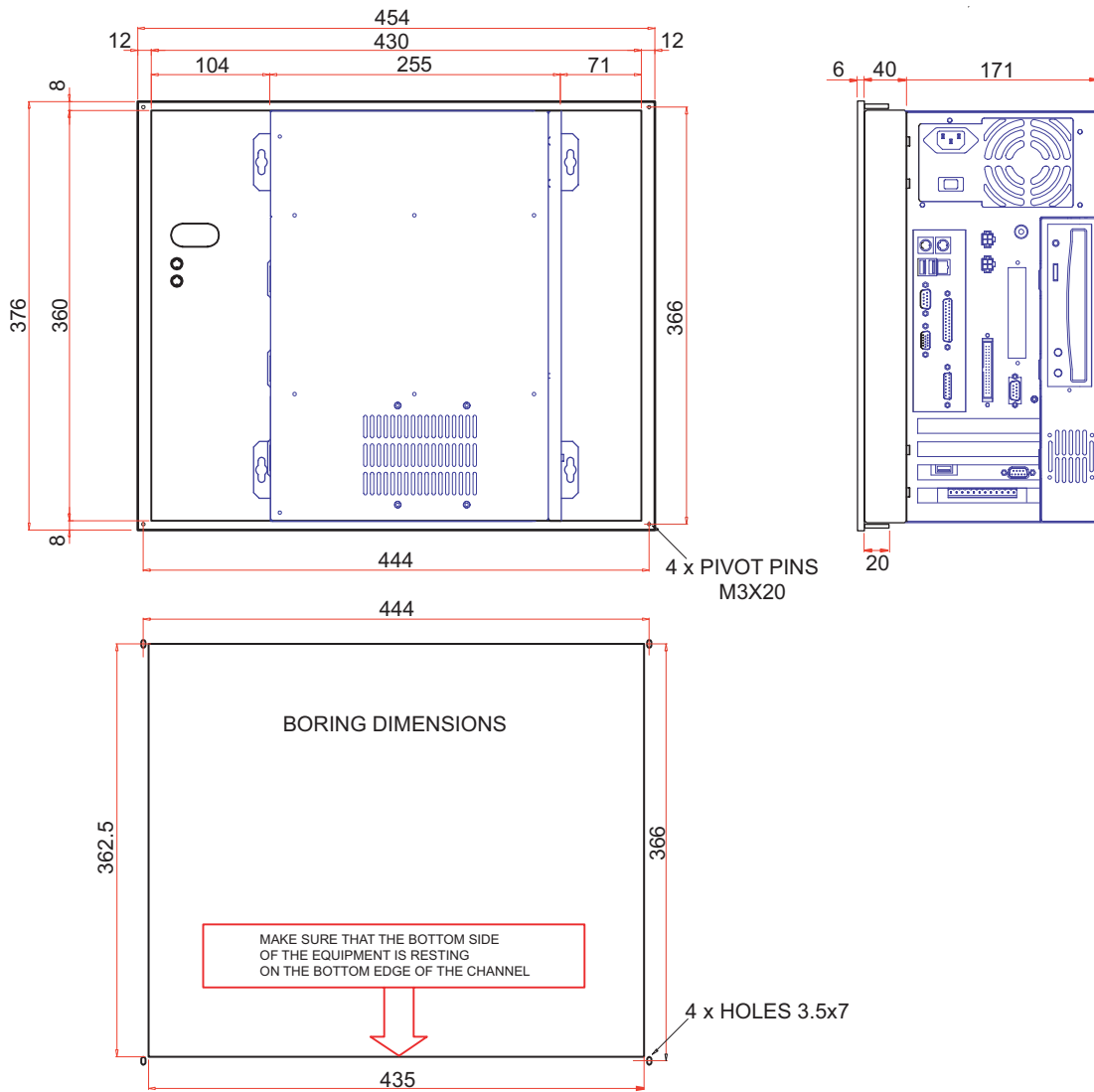

### 4.2.2 Built-in Console CP1022B: dimensions

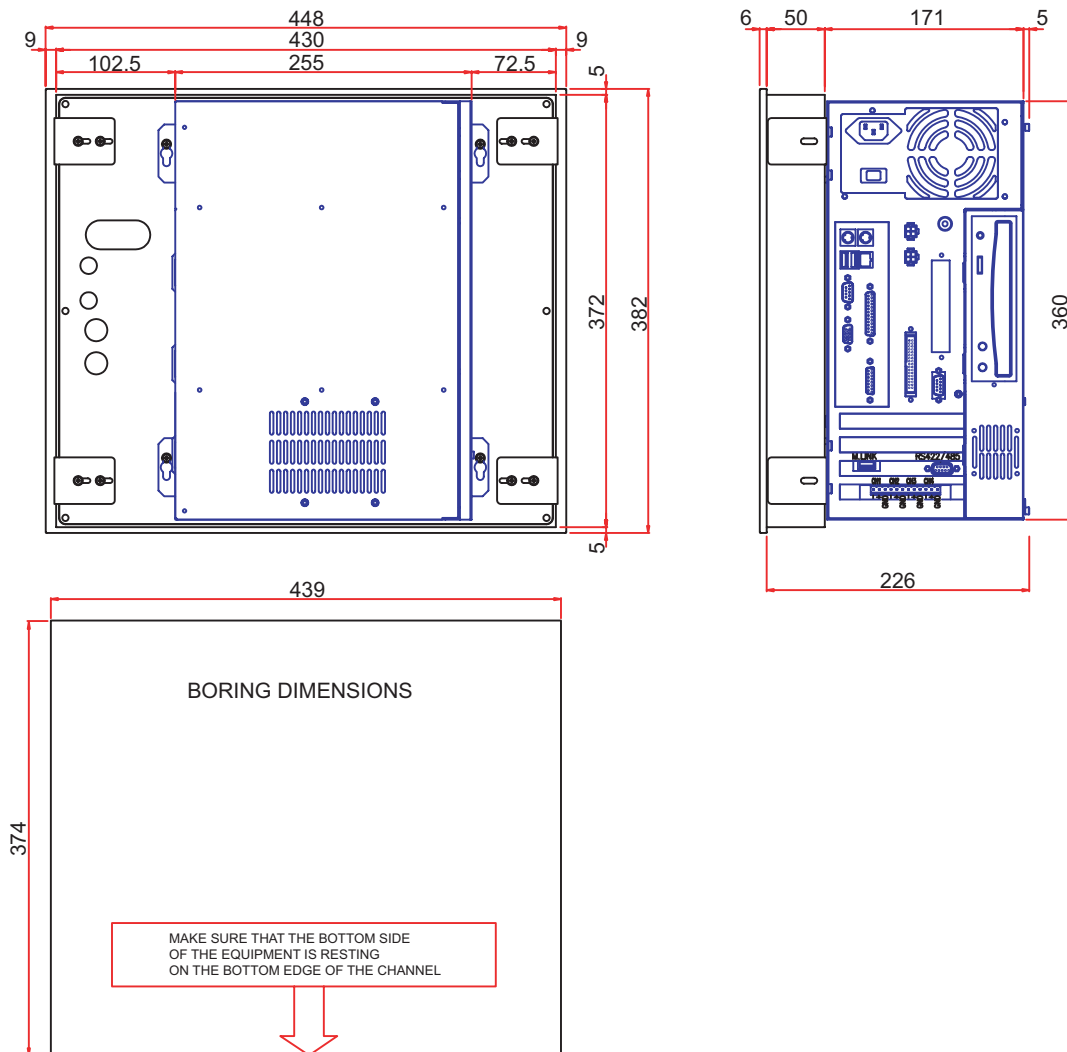

### 4.3 Electrical connections

The mains electricity supply lines must have an adequate power rating and must be protected by a fuse of nominal rating not exceeding 4A.

	<b>It is the user's responsibility to ensure safe isolation between all SELV (or PELV) type cables and components and those of a type other than SELV (or PELV).</b>
---	--

	<b>Never attempt to service, connect or disconnect modules or connectors while the system is powered up.</b>
---	--

	<b>Incorrect connections (power, Fieldbus, or I/O) can cause irreparable damage to the device itself and to other devices connected to it.</b>
---	--

#### Instructions for using connectors

Connectors are not designed to withstand significant torsional or axial forces and must therefore be handled with care and never manipulated with tools.

Before attempting to plug in or unplug a connector, make sure that you can clearly see both connector sections. This is important because incorrect handling can twist or compress the connectors and damage the connectors and their pins.

Proceed as follows to plug in a connector:

- before making the connections, examine the connectors closely and note the exact layout of the pins
- push the male connector gently into the female socket and firmly but gently push it home.

### 4.3.1 CP1x02 Console (Arm connection)

#### Electrical connections (with PM10A card)

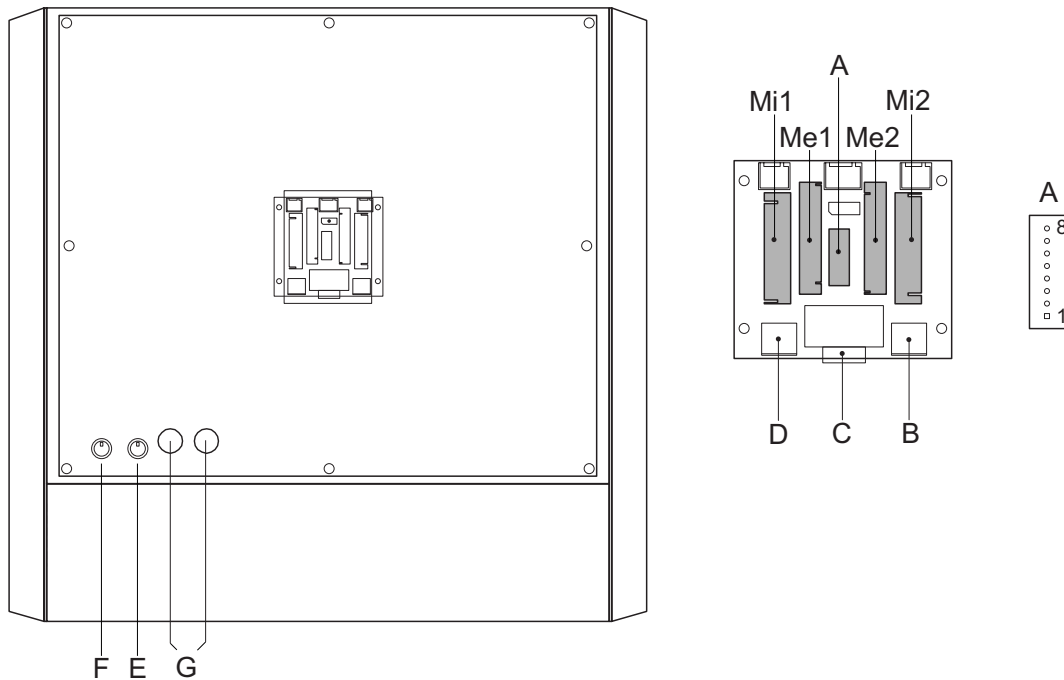

#### Legend:

- A** Power supply & communication connector: to Power supply cable (12v) from numeric control & to PC600 Field-Bus connector
  - 1. Touch Screen: GND
  - 2. Touch Screen: Tx
  - 3. Touch Screen: Rx
  - 4. P801: GND FB (Shield)
  - 5. P801: FB+ (Yellow)
  - 6. P801: FB- (White)
  - 7. Console Power supply: GND (Blue)
  - 8. Console Power supply: +12V (Orange)
- Mi1, Mi2** 12-pin terminal board at 90°: connection of Keys & Emergency (PLC keyboard)
- Me1, Me2** 12-pin terminal board estraibili: connection of PLC keyboard to Machine
- B** PS2 Mouse connector: to PS2 Mouse connector of numerical control
- C** VGA connector: to VGA connector of numerical control
- D** PS2 Keyboard connector: to PS2 Keyboard connector of numerical control
- E** External Mouse input
- F** External Keyboard input
- G** OSD adjuster keys

Electrical connections (with PM10B card)

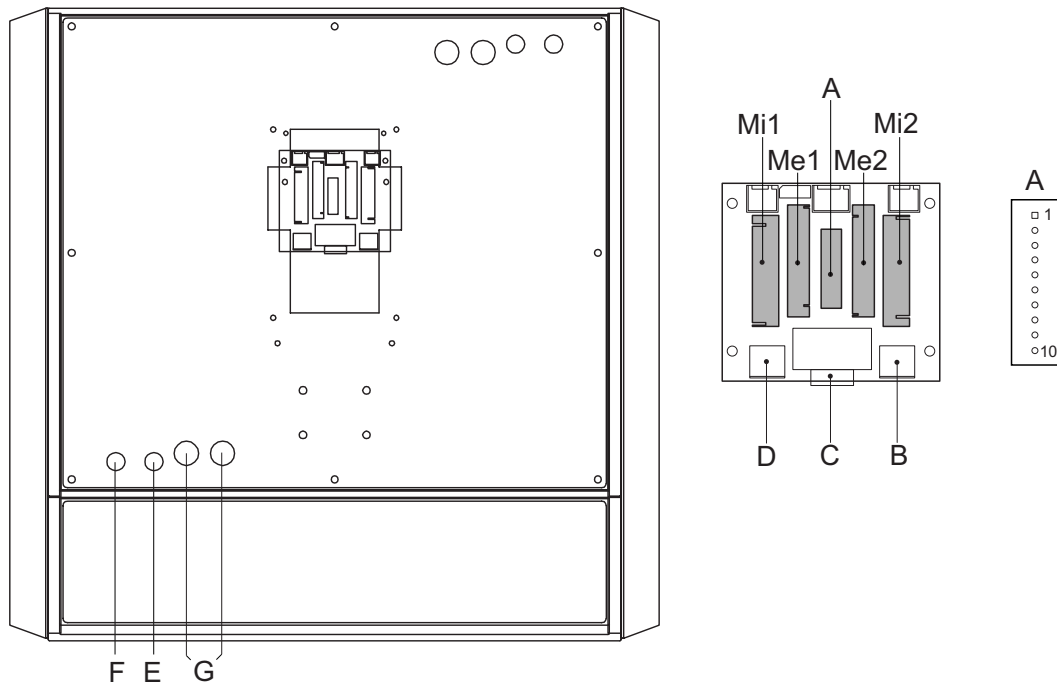

**Legend:**

**A** Power supply & communication connector: to Power supply cable (12v) from numeric control & to PC600 Field-Bus connector

- 1. Touch Screen: GND
- 2. Touch Screen: Tx
- 3. Touch Screen: Rx
- 4. P801: GND FB (Shield)
- 5. P801: FB+ (Yellow)
- 6. P801: FB- (White)
- 7. Console Power supply: GND (Blue)
- 8. Console Power supply: +12V (Orange)
- 9. +5V
- 10. Not connected

**Mi1, Mi2** 12-pin terminal board at 90°: connection of Keys & Emergency (PLC keyboard)

**Me1, Me2** 12-pin terminal board estreibili: connection of PLC keyboard to Machine

- B** PS2 Mouse connector: to PS2 Mouse connector of numerical control
- C** VGA connector: to VGA connector of numerical control
- D** PS2 Keyboard connector: to PS2 Keyboard connector of numerical control
- E** External Mouse input
- F** External Keyboard input
- G** OSD adjuster keys

### 4.3.2 CP1022 Console (Built-in)

#### Electrical connections

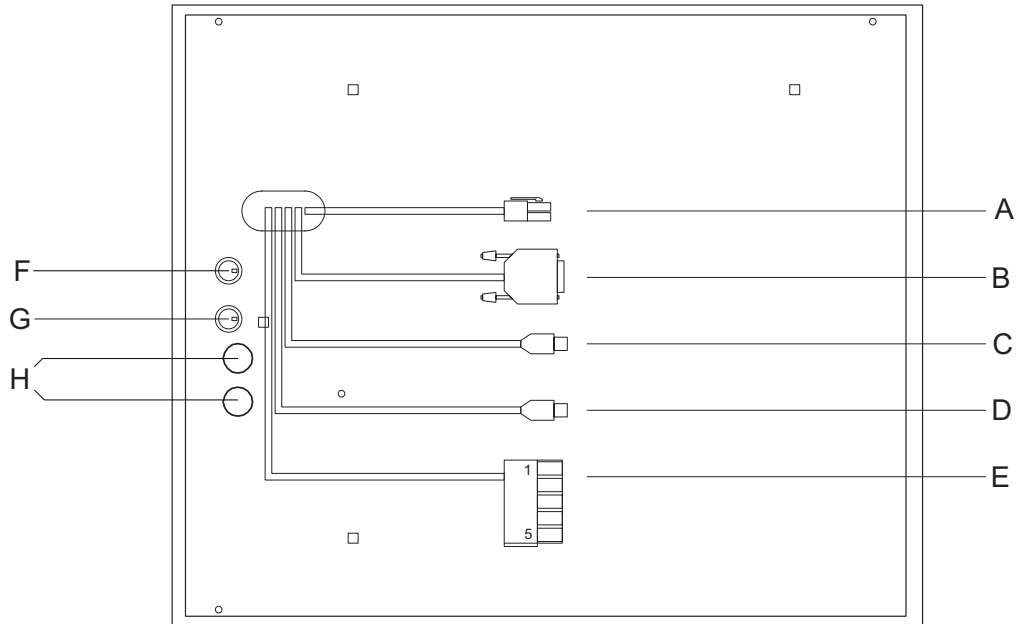

#### Legend:

- A** Console Power supply cable
- B** VGA cable
- C** PS2 Keyboard cable
- D** PS2 Mouse cable
- E** P801connection cable
  - 1. Gnd FB
  - 2. FB+
  - 3. FB-
  - 4. GND
  - 5. Vdc 12V
- F** External Keyboard input
- G** External Mouse input
- H** OSD adjuster keys



## **1 MAINTENANCE**

### **1.1 Scheduled maintenance**

The CP1000 console does not require any special maintenance.

<b>WARNING</b>	Users should not attempt any operations on the module other than those described in Installation.
----------------	---

